

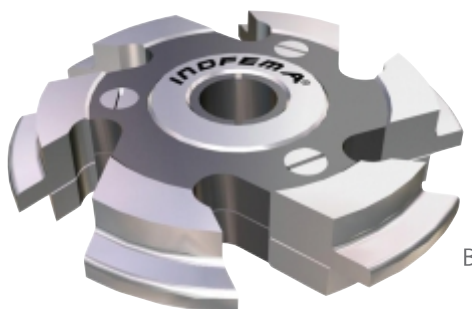

**2010 FRESAS TIPO MACHO E FÊMEA PARA ASSOALHO**

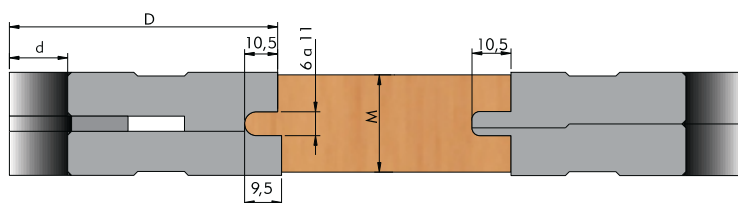

CÓDIGO	UNID.	D	M	d	MÁQ.
2010.01	JG	125	25	30	TUPIA
2010.02	JG	140	25	30	3F
2010.03	JG	140	25	30	4F
2010.04	JG	150	25	40	4F



**2020 FRESAS TIPO MACHO E FÊMEA PARA PAREDES**



CÓDIGO	UNID.	D	M	d	MÁQ.
2020.01	JG	125	25	30	TUPIA
2020.02	JG	140	25	30	3F
2020.03	JG	140	25	30	4F
2020.04	JG	150	25	40	4F

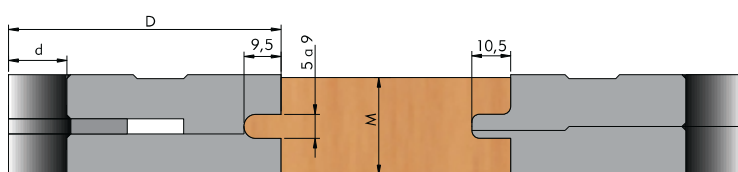



**2040 FRESAS PARA MEIO-FIO**

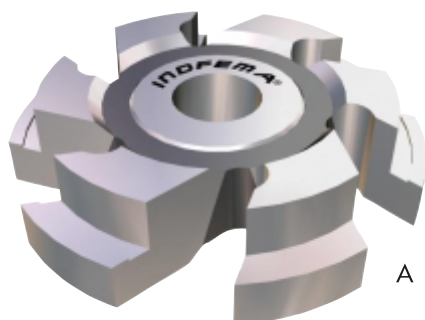

CÓDIGO	UNID.	D	M	d
2040.01	JG	140	25	30
2040.02	JG	150	25	40

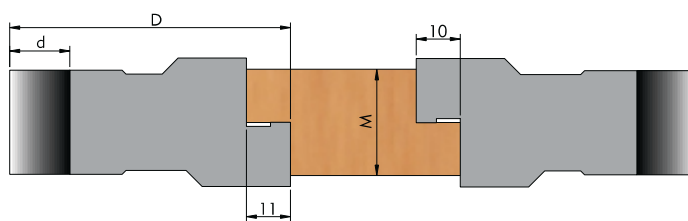

**2070 FRESAS TIPO MACHO E FÊMEA PARA FORRO**



CÓDIGO	UNID.	D	M	d	MÁQ.
2070.01	JG	125	9 a 13	30	TUPIA
2070.03	JG	140	9 a 13	30	4F
2070.04	JG	150	9 a 13	40	4F

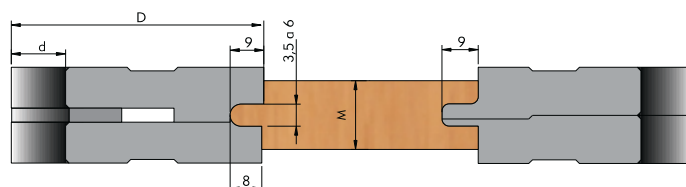



**2080 FRESAS PARA LAMBRIS**

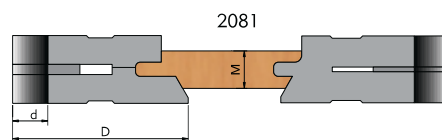
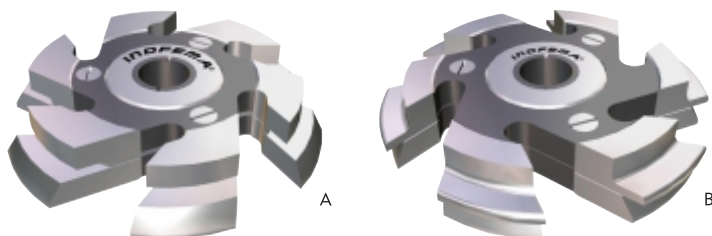

CÓDIGO	UNID.	D	M	MACHO	d	MÁQ.
2081.01	JG	140	9a12	3,5	30	3F
2081.02	JG	140	9a12	3,5	30	4F
2081.03	JG	140	9a12	4	30	4F
2081.04	JG	140	9a12	3,5	30	TUPIA
2081.05	JG	150	9a12	3,5	40	4F
2081.06	JG	150	9a12	4	40	4F
2082.01	JG	140	9a12	3,5	30	3F
2082.02	JG	140	9a12	3,5	30	4F
2082.03	JG	140	9a12	3,5	30	TUPIA
2082.04	JG	150	9a12	3,5	40	4F
2083.01	JG	140	9a12	3,5	30	3F
2083.02	JG	140	9a12	3,5	30	4F
2083.03	JG	140	9a12	3,5	30	TUPIA
2083.04	JG	150	9a12	3,5	40	4F
2084.01	JG	140	9a12	3,5	30	3F
2084.02	JG	140	9a12	3,5	30	4F
2084.03	JG	140	9a12	3,5	30	TUPIA
2084.04	JG	150	9a12	3,5	40	4F
2085.01	JG	140	9a12	3,5	30	4F
2085.02	JG	150	9a12	3,5	40	4F

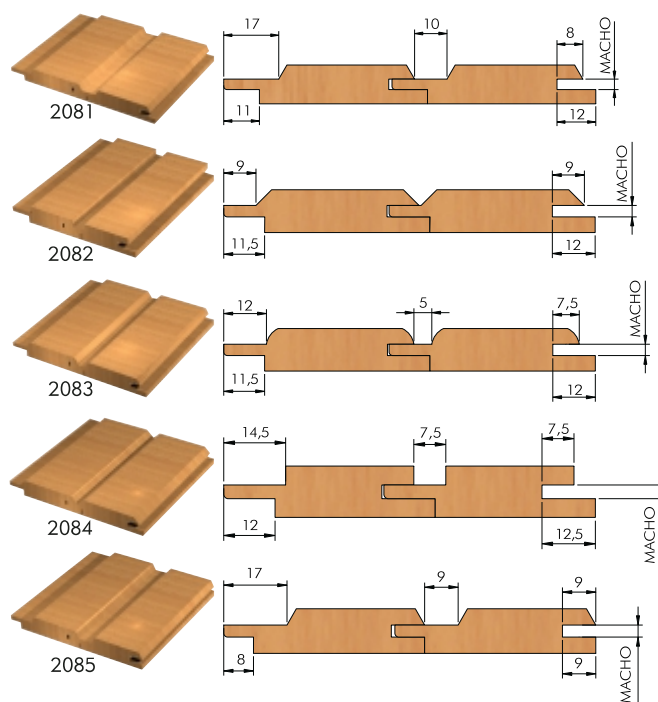

**2090 FRESAS PARA LAMBRIS COM VISTA NOS DOIS LADOS**

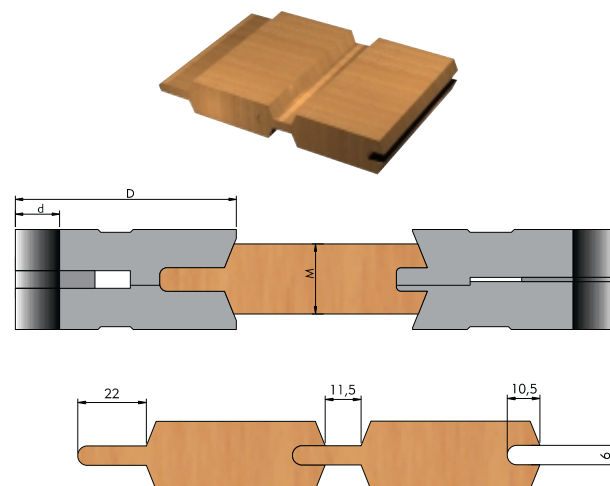
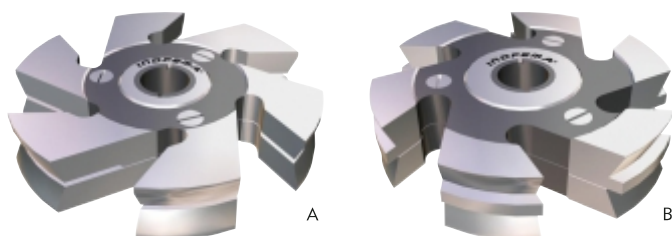

CÓDIGO	UNID.	D	M	d	MÁQ.
2090.01	JG	150	25	30	3F
2090.02	JG	150	25	30	4F
2090.03	JG	150	25	30	TUPIA
2090.04	JG	150	25	40	4F



**2110 FRESAS PARA PORTA DE CALHA (TUPIA)**

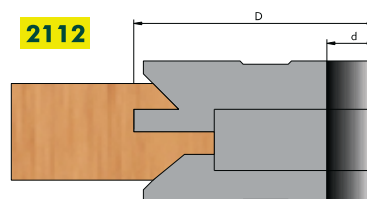
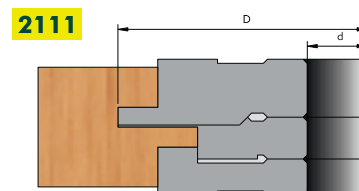

CÓDIGO	UNID.	D	M	d
2111.01	JG	140	20/30	30
2112.01	JG	140	20/25	30

**2120 FRESAS PARA PORTA MEXICANA**

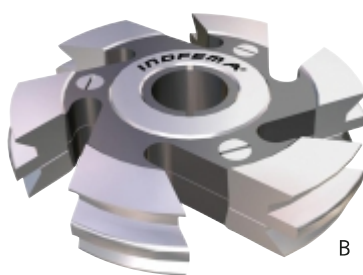
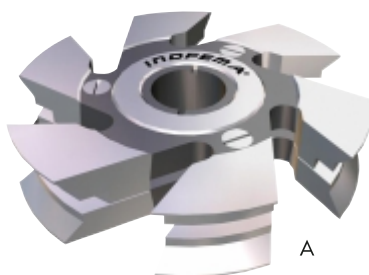

CÓDIGO	UNID.	D	M	d	MÁQ.
2121.02	JG	150	25	30	4F
2121.03	JG	150	25	30	TUPIA
2121.04	JG	150	25	40	4F
2122.02	JG	150	35	30	4F
2122.03	JG	150	35	30	TUPIA
2122.04	JG	150	35	40	4F

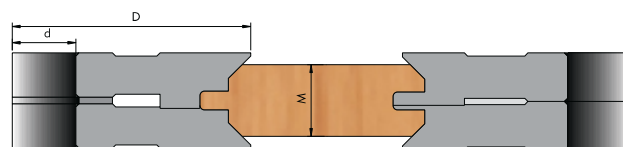



**2170 FRESAS PARA CAIXILHO**

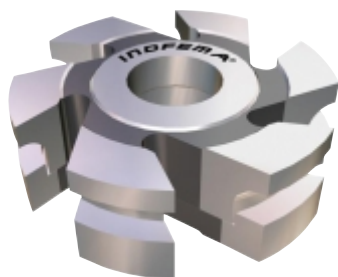

PERFIL 2170.03



CONTRA-PERFIL 2171.03



CONTRA-PERFIL 2172.03

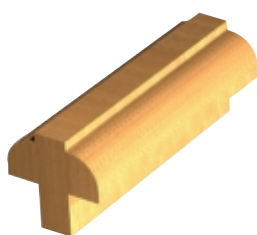
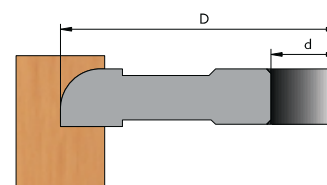
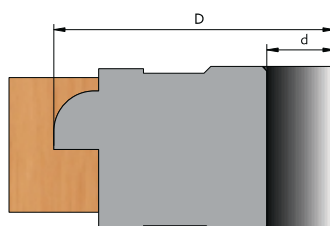
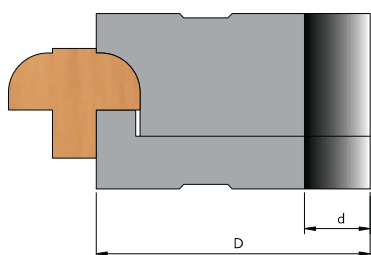

CÓDIGO	UNID.	D	M	d
<b>2170.03</b>	PC	125	35	30
<b>2171.03</b>	PC	125	35	30
<b>2172.03</b>	PC	125	35	30



## 2180 FRESAS PARA PORTAS MOLDURADAS

### 2181 PARA MÁQUINA RESPIGADEIRA OMIL

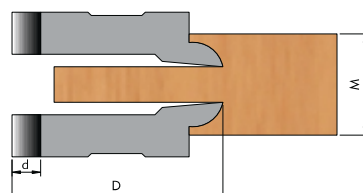
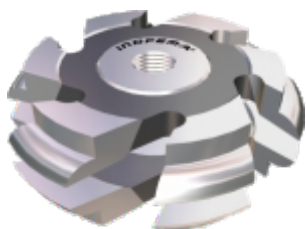

### 2182 PARA MÁQUINA TUPIA

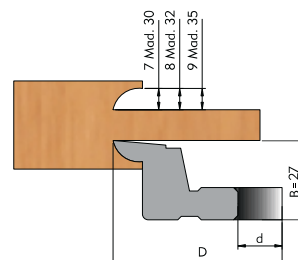

### 2183 PARA MÁQUINA TUPIA

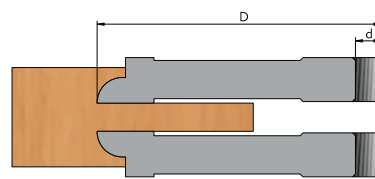
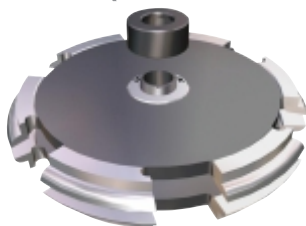

### 2184 PARA MÁQUINA TUPIA

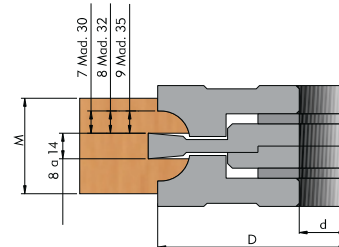
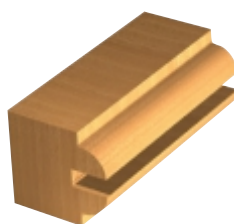

CÓDIGO	UNID.	D	M	d
2181.01	JG	125	30	OMIL
2181.02	JG	125	32	OMIL
2181.03	JG	125	35	OMIL
2181.04	JG	125	30	30
2181.05	JG	125	32	30
2181.06	JG	125	35	30
2182.01	PC	125	30	30
2182.02	PC	125	32	30
2182.03	PC	125	35	30
2182.04	PC	150	30	30

CÓDIGO	UNID.	D	M	d
2183.01	JG	250	30	30
2183.02	JG	250	32	30
2183.03	JG	250	35	30
2184.01	JG	125	30	30
2184.02	JG	125	32	30
2184.03	JG	125	35	30





**2200**

**FRESA PARA REBAIXE DO MARCO DE PORTA "BATENTE OU DUELAS"**

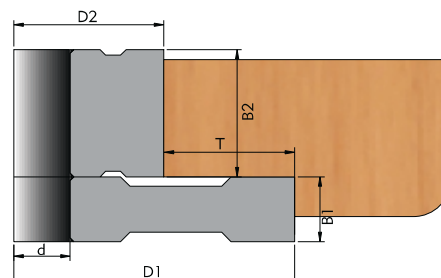
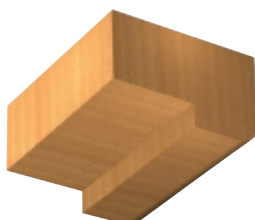
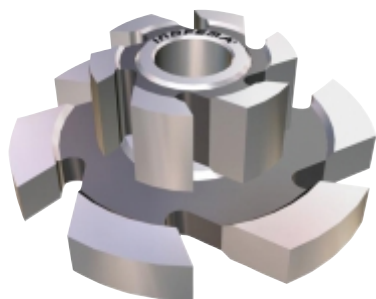

CÓDIGO	UNID.	D1	B1	T	d
2201.01	PC	150	17	-	30
CÓDIGO	UNID.	D2	B2	T	d
2202.01	PC	90	34	30	30
2202.02	PC	86	34	32	30
2202.03	PC	80	34	35	30
2202.04	PC	76	34	37	30

CÓDIGO	UNID.	D1	B1	T	d
2201.02	PC	150	17	-	40
CÓDIGO	UNID.	D2	B2	T	d
2202.05	PC	90	34	30	40
2202.06	PC	86	34	32	40
2202.07	PC	80	34	35	40
2202.08	PC	76	34	37	40

**2220**

**FRESA PARA MEIA-CANA**

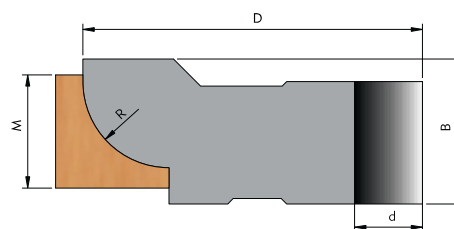
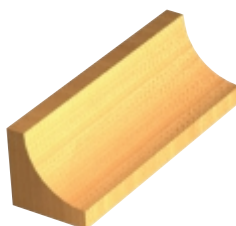
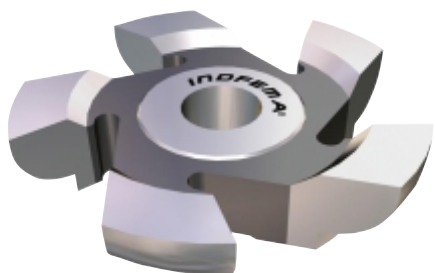

CÓDIGO	LADO	UNID.	D	B	M	R	d
2221.01	D	PC	125	30	23	17,5	30
2221.02	E	PC	125	30	23	17,5	30
2222.01	D	PC	125	32	25	19,0	30
2222.02	E	PC	125	32	25	19,0	30

CÓDIGO	LADO	UNID.	D	B	M	R	d
2223.01	D	PC	125	36	30	23,5	30
2223.02	E	PC	125	36	30	23,5	30
2224.01	D	PC	125	42	35	27,0	30
2224.02	E	PC	125	42	35	27,0	30



**2230**

**FRESA PARA RODAPÉS TIPO "PEITO DE ROLA"**

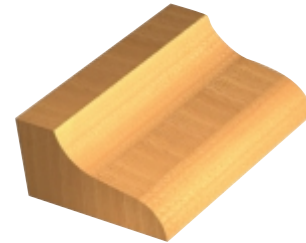

CÓDIGO	LADO	UNID.	D	B	M	T	d
2231.01	D	PC	150	30	25	35	30
2231.02	E						

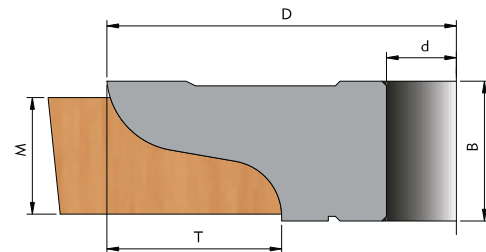

**2240**

**FRESAS PARA MATAJUNTA SIMPLES**

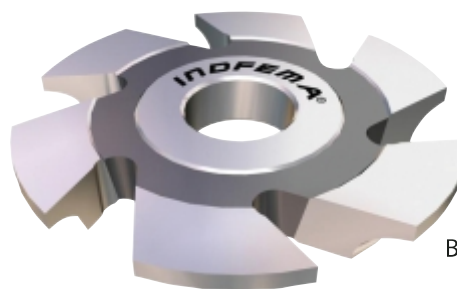

CÓDIGO	UNID.	D	M	d
2240.01	JG	125	10	30
2240.02	JG	125	12	30

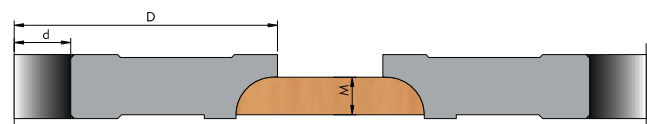





**2250**

**FRESA PARA RODAPÉS BOLEADOS**

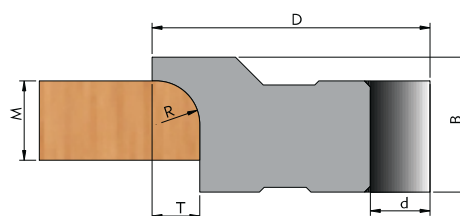
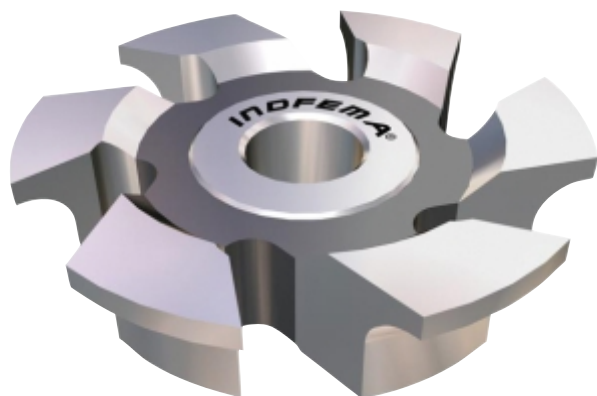

CÓDIGO	LADO	UNID.	D	B	M	T	R	d
2251.01	D	PC	125	33	25	13	11,5	30
2251.02	E							

**2260**

**FRESA PARA DESQUINAR**

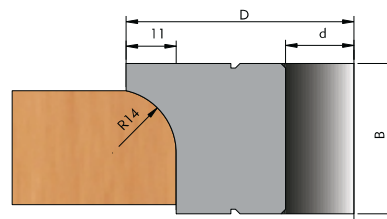

CÓDIGO	LADO	UNID.	D	B	d
2260.01	D	PC	100	34	30
2260.02	E				



**2290**

**FRESA PARA CORDÃO DE JANELA**

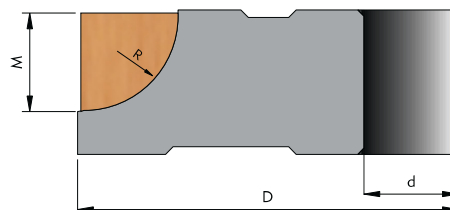

CÓDIGO	LADO	UNID.	D	M/R	d
2290.01	D	PC	80	8	30
2290.02	E	PC	80	8	30
2290.03	D	PC	80	10	30
2290.04	E	PC	80	10	30
2290.05	D	PC	80	12	30
2290.06	E	PC	80	12	30
2290.07	D	PC	80	12,5	30
2290.08	E	PC	80	12,5	30
2290.09	D	PC	80	15	30
2290.10	E	PC	80	15	30
2290.11	D	PC	100	8	30
2290.12	E	PC	100	8	30
2290.13	D	PC	100	10	30
2290.14	E	PC	100	10	30
2290.15	D	PC	100	12	30
2290.16	E	PC	100	12	30
2290.17	D	PC	100	12,5	30
2290.18	E	PC	100	12,5	30
2290.19	D	PC	100	15	30
2290.20	E	PC	100	15	30

CÓDIGO	LADO	UNID.	D	M/R	d
2290.21	D	PC	100	17,5	30
2290.22	E	PC	100	17,5	30
2290.23	D	PC	100	20	30
2290.24	E	PC	100	20	30
2290.27	D	PC	125	10	30
2290.28	E	PC	125	10	30
2290.29	D	PC	125	12	30
2290.30	E	PC	125	12	30
2290.31	D	PC	125	15	30
2290.32	E	PC	125	15	30
2290.33	D	PC	125	20	30
2290.34	E	PC	125	20	30
2290.35	D	PC	125	25	30
2290.36	E	PC	125	25	30
2290.37	D	PC	125	30	30
2290.38	E	PC	125	30	30
2290.39	D	PC	150	35	30
2290.40	E	PC	150	35	30

**2320**

**FRESA PARA MOLDURA DE BATENTE DE VENEZIANA**

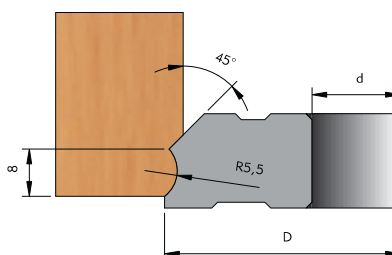

CÓDIGO	UNID.	D	d
2320.01	PC	80	30



**2370**

**FRESA PARA PERFIS MÚLTIPLOS**

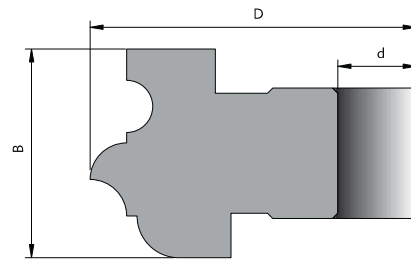

CÓDIGO	UNID.	D	B	d
2370.01	PC	125	40	30

1 PASSADA

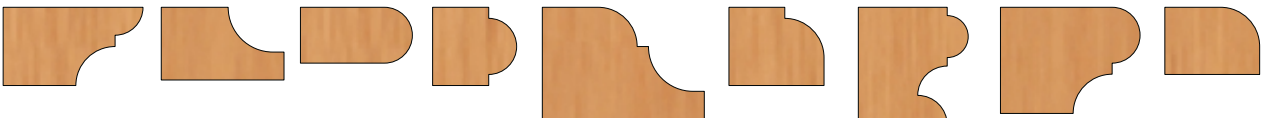

2 PASSADAS

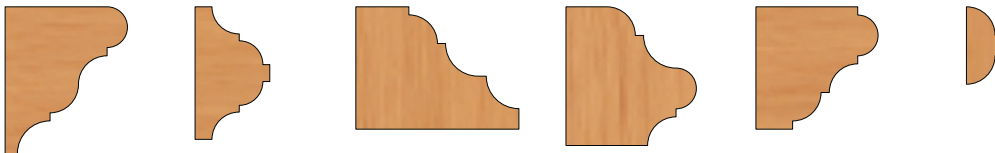

**2400**

**FRESAS PARA MOLDURAS**

**2401**

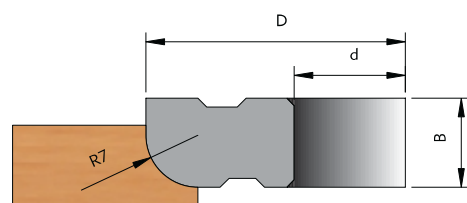

CÓDIGO	LADO	UNID.	D	B	d
2401.01	D	PC	80	12	30
2401.02	E				



**2400**

**FRESAS PARA MOLDURAS**

**2402**

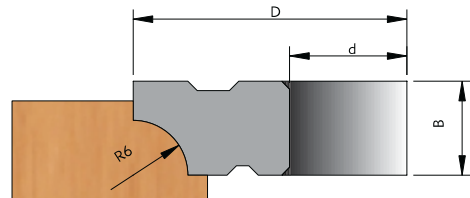

CÓDIGO	LADO	UNID.	D	B	d
2402.01	D	PC	80	12	30
2402.02	E	PC	80	12	30

**2403**

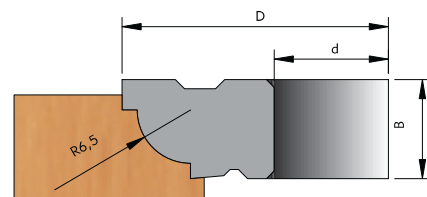
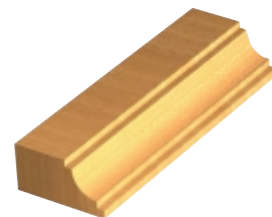

CÓDIGO	LADO	UNID.	D	B	d
2403.01	D	PC	80	13	30
2403.02	E	PC	80	13	30



**2400**

**FRESAS PARA MOLDURAS**

**2404**

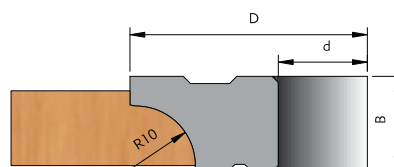
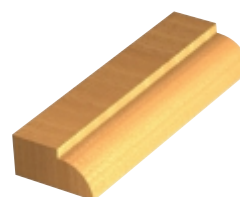
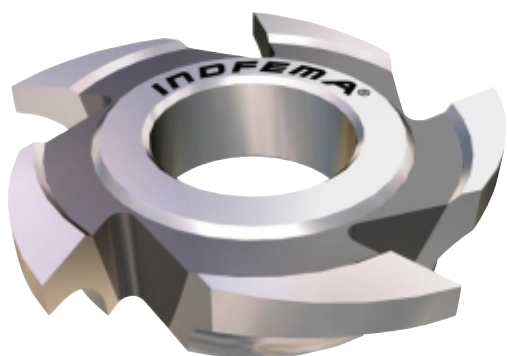

CÓDIGO	LADO	UNID.	D	B	d
2404.01	D	PC	80	16	30
2404.02	E				

**2405**

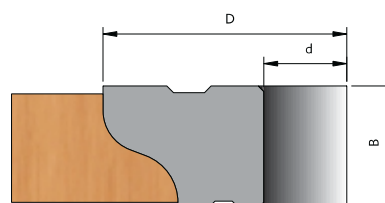

CÓDIGO	LADO	UNID.	D	B	d
2405.01	D	PC	100	22	30
2405.02	E				



CÓDIGO	LADO	UNID.	D	B	d
2411.01	D	PC	80	18	30
2411.02	E				
2414.01	D	PC	80	16	30
2414.02	E				
2416.01	D	PC	80	17	30
2416.02	E				
2417.01	D	PC	80	15	30
2417.02	E				
2419.01	D	PC	100	18	30
2419.02	E				
2420.01	D	PC	100	18	30
2420.02	E				
2422.01	D	PC	100	19	30
2422.02	E				
2423.01	D	PC	100	25	30
2423.02	E				
2424.01	D	PC	100	18	30
2424.02	E				
2427.01	D	PC	80	16	30
2427.02	E				

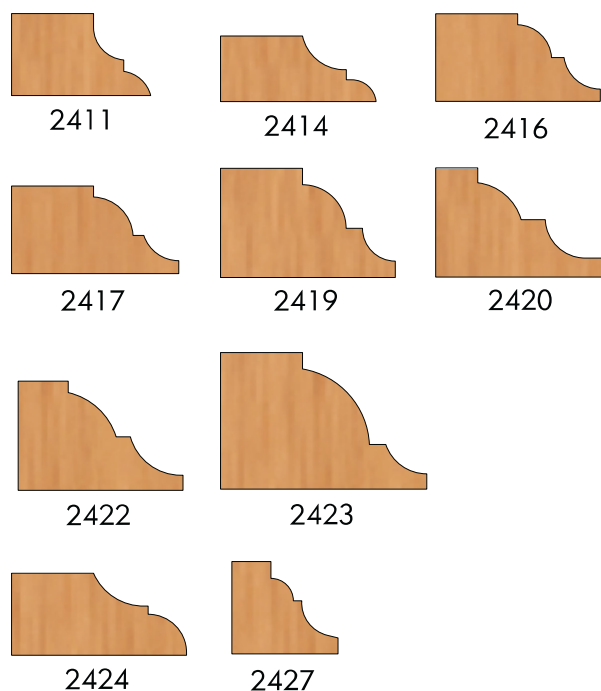

**2530**

**FRESA PARA MEIA-ESQUADRIA 45°**

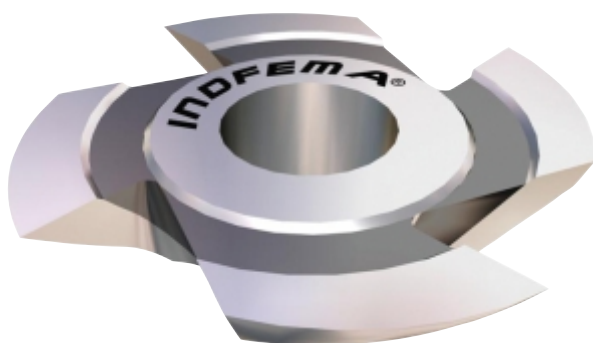

CÓDIGO	LADO	UNID.	D	B	M	d
2530.01	D	PC	100	25	23	30
2530.02	E					
2530.03	D	PC	115	30	28	30
2530.04	E					
2530.05	D	PC	125	35	33	30
2530.06	E					
2530.07	D	PC	140	40	38	30
2530.08	E					

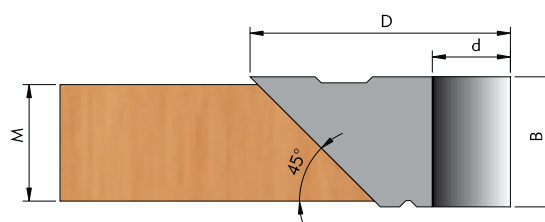





**2540**

**FRESA PARA CANAL REDONDO**

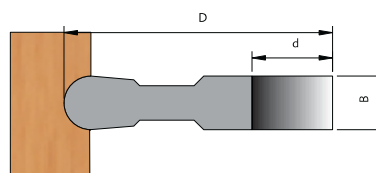
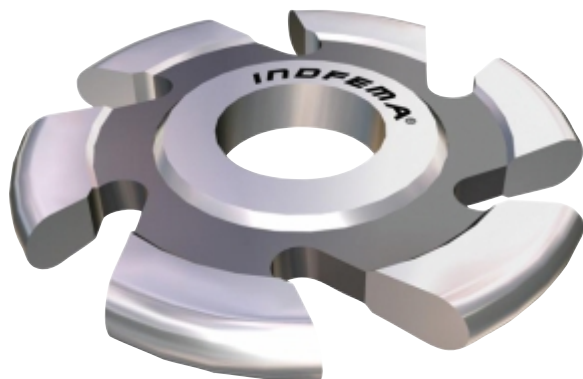

CÓDIGO	UNID.	D	B	d
2540.01	PC	100	7	30
2540.02	PC	100	8	30
2540.03	PC	100	10	30
2540.04	PC	100	12	30

CÓDIGO	UNID.	D	B	d
2540.05	PC	100	15	30
2540.06	PC	100	20	30
2540.07	PC	100	25	30
2540.08	PC	100	30	30

**2550**

**FRESAS PARA CANAL REDONDO MÚLTIPLO**

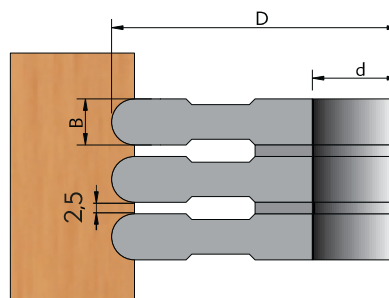
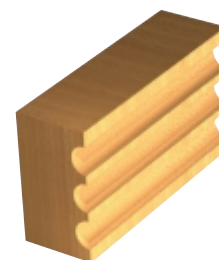

CÓDIGO	UNID.	D	B	d
2551.01	JG	100	7	30
2551.02	JG	100	8	30

Obs: Uso também para molduras de móveis e carrocerias



**2560**

**FRESA PARA TALINHA DE VENEZIANA**

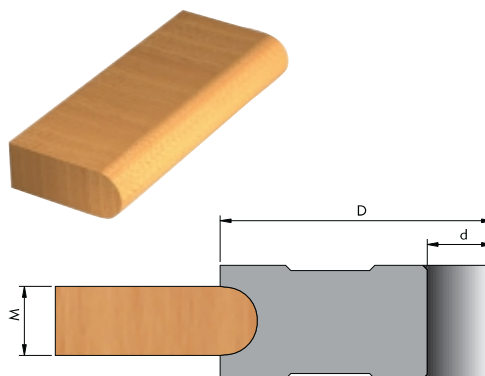

CÓDIGO	UNID.	D	M	d
2560.01	PC	80	8	30
2560.02	PC	80	10	30
2560.03	PC	80	12	30
2560.04	PC	80	15	30
2560.05	PC	80	20	30
2560.06	PC	100	8	30
2560.07	PC	100	10	30
2560.08	PC	100	12	30
2560.09	PC	100	15	30
2560.10	PC	100	20	30
2560.11	PC	100	22	30

CÓDIGO	UNID.	D	M	d
2560.12	PC	100	25	30
2560.13	PC	100	30	30
2560.14	PC	100	35	30
2560.16	PC	125	10	30
2560.17	PC	125	12	30
2560.18	PC	125	15	30
2560.19	PC	125	20	30
2560.20	PC	125	25	30
2560.21	PC	125	30	30
2560.22	PC	125	35	30

**2570**

**FRESA PARA BARRA DE CAMA**

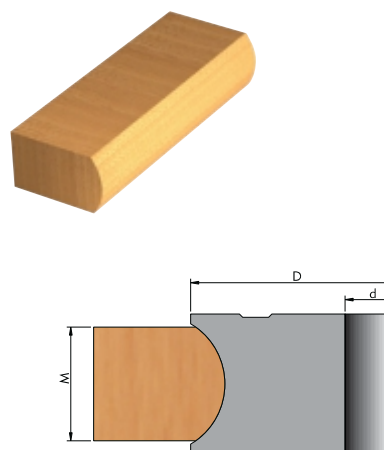

CÓDIGO	UNID.	D	M	d
2570.01	PC	125	20	30
2570.02	PC	125	22	30
2570.03	PC	125	25	30



**2700**

**FRESAS PARA ALMOFADAS**



2706

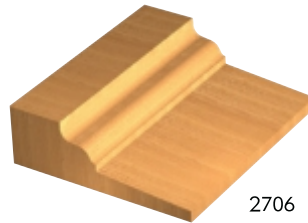

2706

CÓDIGO	UNID.	D	B	d
2701.01	PC	165	18	30
2702.01	PC	165	18	30
2705.01	PC	165	18	30
2706.01	PC	165	22	30
2707.01	PC	165	20	30
2708.01	PC	165	18	30
2709.01	PC	165	18	30
2710.01	PC	165	22	30
2711.01	PC	165	18	30

CÓDIGO	UNID.	D	B	d
2713.01	PC	165	20	30
2715.01	PC	165	20	30
2716.01	PC	165	20	30
2719.01	PC	165	23	30
2720.01	PC	165	22	30
2721.01	PC	165	23	30
2722.01	PC	165	18	30
2723.01	PC	165	22	30
2724.01	PC	165	25	30

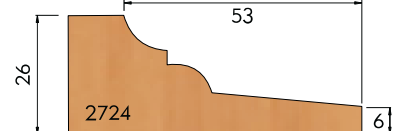
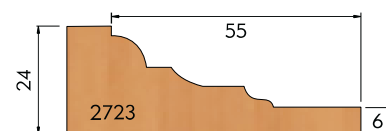
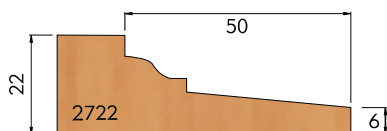
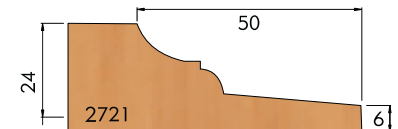
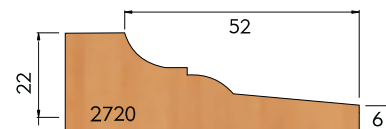
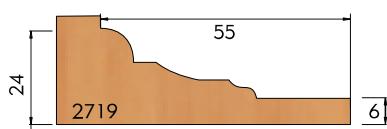
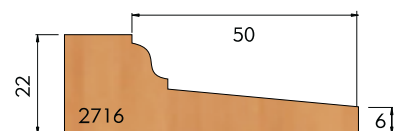
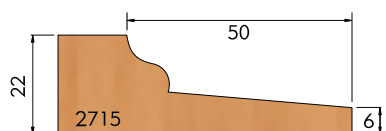
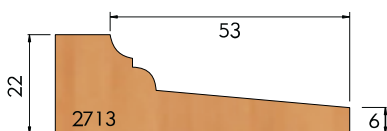
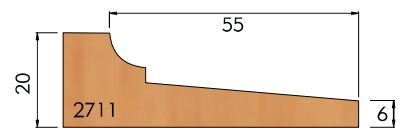
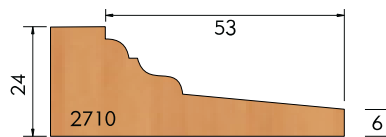
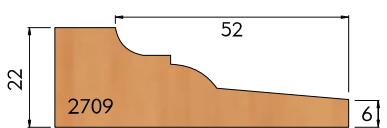
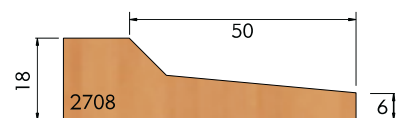
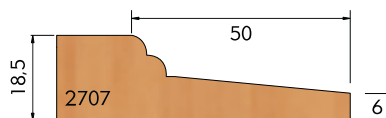
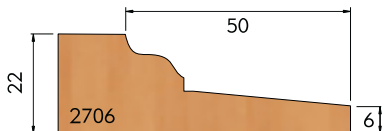
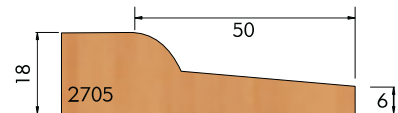
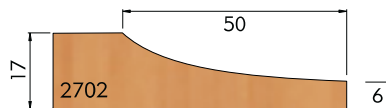
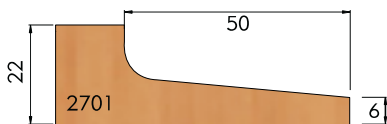



**2760**

**FRESA PARA ALMOFADAS "TIPO CRUZEIRO"**



**2761**

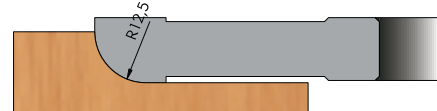

**2762**

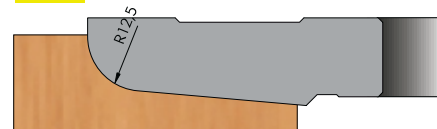

CÓDIGO	UNID.	D	d
<b>2761.01</b>	PC	165	30
<b>2762.01</b>	PC	165	30

**2780**

**FRESAS PARA REJUNTE**

**2781**

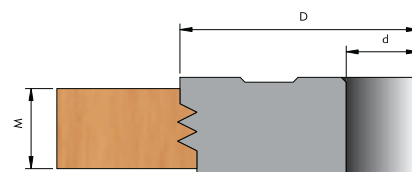
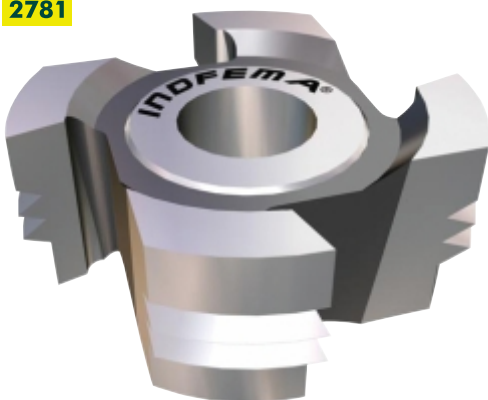

CÓDIGO	UNID.	D	M	d
<b>2781.01</b>	PC	100	35	30
<b>2781.02</b>	PC	100	35	40



**2780**

**FRESAS PARA REJUNTE**

**2784**

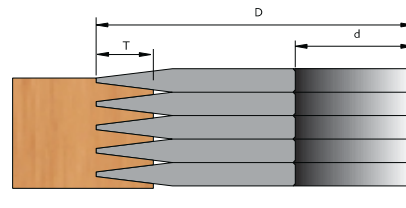
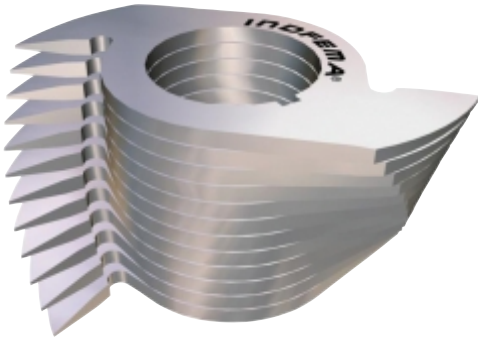

CÓDIGO	UNID.	D	T	B	d
<b>2784.01</b>	PC	135	13	5	50
<b>2784.02</b>	PC	135	13	10	50

**2785**

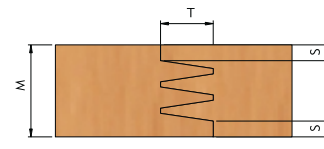
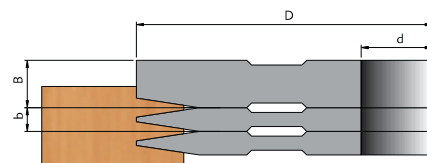
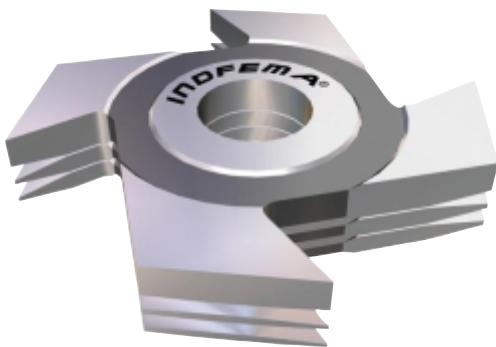

CÓDIGO	UNID.	D	B	d
<b>2785.01</b>	PC	125	5	30
<b>2785.02</b>	PC	125	10	30



**2800**

**FRESA PARA RANHURA**

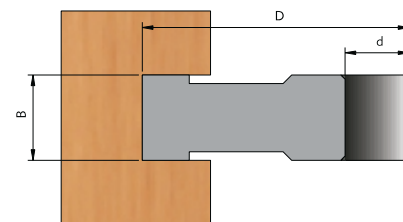
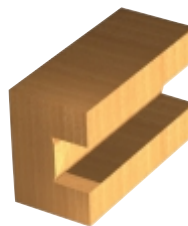
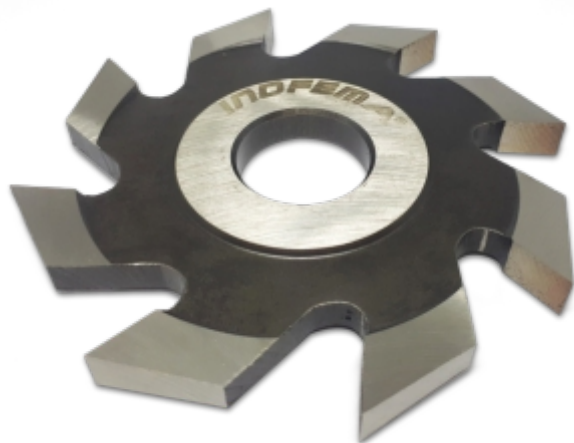

CÓDIGO	UNID.	D	B	d
<b>2800.01</b>	PC	100	4	30
<b>2800.02</b>	PC	100	5	30
<b>2800.03</b>	PC	100	6	30
<b>2800.04</b>	PC	100	7	30
<b>2800.05</b>	PC	100	8	30
<b>2800.06</b>	PC	100	9	30
<b>2800.07</b>	PC	100	10	30
<b>2800.08</b>	PC	100	12	30
<b>2800.09</b>	PC	100	15	30
<b>2800.10</b>	PC	100	20	30
<b>2800.11</b>	PC	100	25	30
<b>2800.12</b>	PC	100	30	30
<b>2800.13</b>	PC	125	4	30
<b>2800.14</b>	PC	125	5	30
<b>2800.15</b>	PC	125	6	30
<b>2800.16</b>	PC	125	7	30
<b>2800.17</b>	PC	125	8	30

CÓDIGO	UNID.	D	B	d
<b>2800.18</b>	PC	125	9	30
<b>2800.19</b>	PC	125	10	30
<b>2800.20</b>	PC	125	12	30
<b>2800.21</b>	PC	125	15	30
<b>2800.22</b>	PC	125	20	30
<b>2800.40</b>	PC	125	22	30
<b>2800.23</b>	PC	125	25	30
<b>2800.24</b>	PC	125	30	30
<b>2800.27</b>	PC	150	6	30
<b>2800.29</b>	PC	150	8	30
<b>2800.30</b>	PC	150	9	30
<b>2800.31</b>	PC	150	10	30
<b>2800.32</b>	PC	150	12	30
<b>2800.33</b>	PC	150	15	30
<b>2800.34</b>	PC	150	20	30
<b>2800.35</b>	PC	150	25	30
<b>2800.36</b>	PC	150	30	30





**2810**

**FRESA REGULÁVEL PARA RANHURA COM RISCADOR**

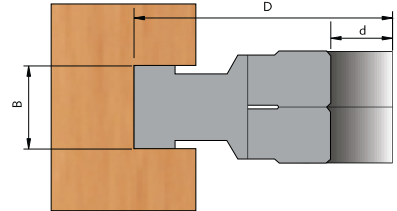
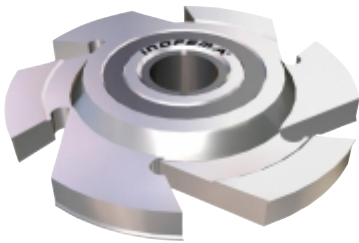

CÓDIGO	UNID.	D	B	d
2810.01	JG	100	4/7	30
2810.02	JG	100	5/9	30
2810.03	JG	100	7/13	30
2810.04	JG	100	8/15	30
2810.05	JG	100	9/17	30
2810.06	JG	100	10/19	30
2810.07	JG	125	4/7	30
2810.08	JG	125	5/9	30

CÓDIGO	UNID.	D	B	d
2810.09	JG	125	7/13	30
2810.10	JG	125	8/15	30
2810.11	JG	125	9/17	30
2810.12	JG	125	10/19	30
2810.13	JG	125	13/25	30
2810.14	JG	125	15/29	30
2810.15	JG	125	20/39	30
2810.16	JG	125	25/49	30

**2820**

**FRESA LISA PARA REBAIXE**

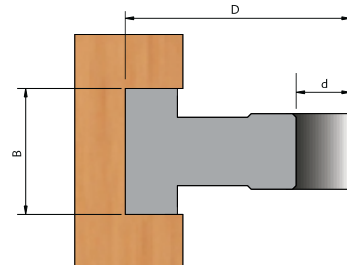

CÓDIGO	UNID.	D	B	d
2820.01	PC	80	32	30
2820.02	PC	80	35	30
2820.03	PC	80	40	30
2820.04	PC	80	45	30
2820.05	PC	80	50	30
2820.06	PC	80	55	30
2820.07	PC	80	60	30
2820.08	PC	100	32	30
2820.09	PC	100	35	30
2820.10	PC	100	40	30
2820.11	PC	100	45	30
2820.12	PC	100	50	30
2820.13	PC	100	55	30
2820.14	PC	100	60	30

CÓDIGO	UNID.	D	B	d
2820.15	PC	125	32	30
2820.16	PC	125	35	30
2820.17	PC	125	40	30
2820.18	PC	125	45	30
2820.19	PC	125	50	30
2820.20	PC	125	55	30
2820.21	PC	125	60	30
2820.30	PC	150	32	30
2820.31	PC	150	35	30
2820.32	PC	150	40	30
2820.33	PC	150	45	30
2820.34	PC	150	50	30
2820.35	PC	150	55	30
2820.36	PC	150	60	30



**2900**

**FRESAS PARA MOLDURAS DE MÓVEIS E CARROCERIAS**

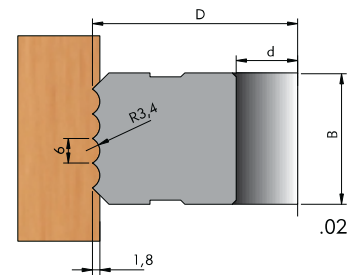
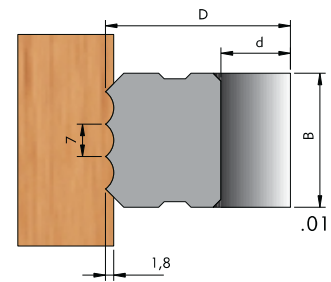
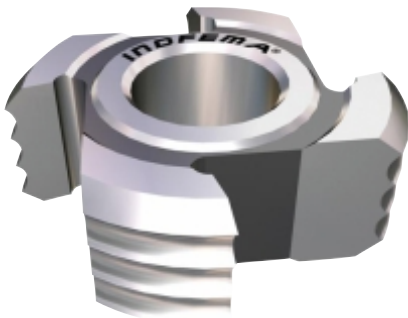

CÓDIGO	UNID.	D	B	d
2900.01	PC	80	29	30
2900.02	PC	80	32	30

**2910**

**FRESA PARA ABRIR RASGO EM PORTA DE CALHA**

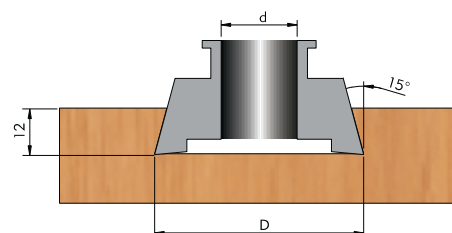
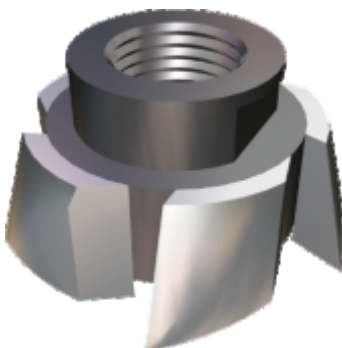

CÓDIGO	UNID.	D	ROSCA	d
2910.01	PC	55	D	OMIL
2910.02	PC	55	E	OMIL